

LONG-STROKE ROLLING DIAPHRAGMS BFA

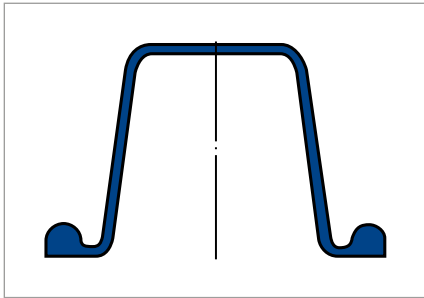

Long-Stroke Rolling Diaphragms BFA

PRODUCT DESCRIPTION

Long-stroke rolling diaphragms are thin-walled, special sensitive diaphragms made from highly elastic materials with fabric reinforcement.

Along with this standard design type BFA, the long-stroke rolling diaphragms can also be supplied made in special tools without fabric, type BFAO.

PRODUCT ADVANTAGES

The small diaphragm thickness and large height of the diaphragm relative to the diameter provide the following advantages:

- Low, almost constant resistance to movement over the entire stroke
- Considerably greater stroke lengths in comparison to conventional diaphragms with the same diameter
- Effective area remains the same over entire stroke
- No additional resistance to movement on starting or on change in direction of movement; no notch point in operating range
- Low requirements on piston and cylinder in comparison to lip seals.

APPLICATION

Long-stroke rolling diaphragms are used in hydraulically and pneumatically-activated control and regulation equipment, pressure switches and pressure transducers as well as measuring and display equipment. In the design without fabric, they are used at low pressures.

MATERIAL

Standard material: 50 NBR 253 based on acrylonitrile-butadiene rubber (NBR) with or without polyester fabric → Technical Manual.

Details on general structure of long-stroke rolling diaphragms and the properties of the elastomers → Technical Manual.

Rolling diaphragms made from silicone rubber, fluoro rubber and EPDM with fabric are only produced to a height of $H_{\max} = 0,6 D_g$ (D_g = cylinder diameter).

OPERATING CONDITIONS

The standard range BFA made from nitrile rubber with fabric reinforcement for use in compressed air and mineral oils permits operating pressures up to 10 bar and test pressures up to 15 bar. Special qualities are available on enquiry for applications involving town gas and natural gas, petrol and brake fluids as well as for high thermal loads.

The type BFAO should only be used when the operating pressure does not exceed 1,5 bar. Low longitudinal elongation must be taken into account.

In operation, even with piston return, a low pressure difference of approx. 0,15 bar must be present for all designs, otherwise folds or kinks will form in the rolling convolution. This counter pressure can be achieved using a regulator valve. A ventilation hole must be provided to prevent a pressure build-up on the non-pressurised side.

FITTING & INSTALLATION

Long-stroke rolling diaphragms with fabric layer, the fabric must be on the non-pressurised side. The diaphragm is inverted before fitting. Should the rolling convolution formed in this way arch upwards when performing this action, the use of a mounting sleeve is necessary.

Do not use a screwdriver!

Another possible fitting method: fit inverted rolling diaphragm to the piston, place bead in the groove and push piston into the cylinder. In this way the rolling convolution is formed. The piston must be secured against twisting after fitting to avoid the formation of a skewed convolution. A plain washer is sufficient as the spring support. Stroke limiting is always to be provided. The rolling area for the diaphragm must be finely machined and polished. The transition radii on the clamping flange, piston base and cover plate are to be smooth and free from scoring.

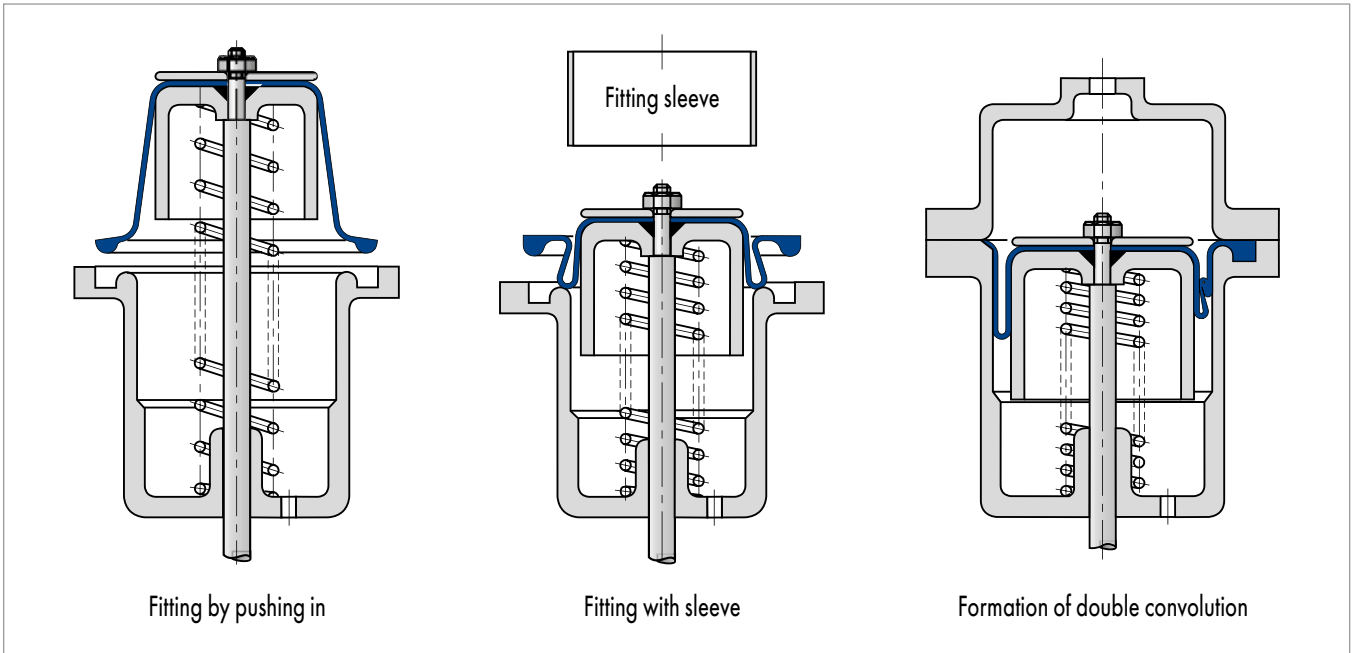

Fitting

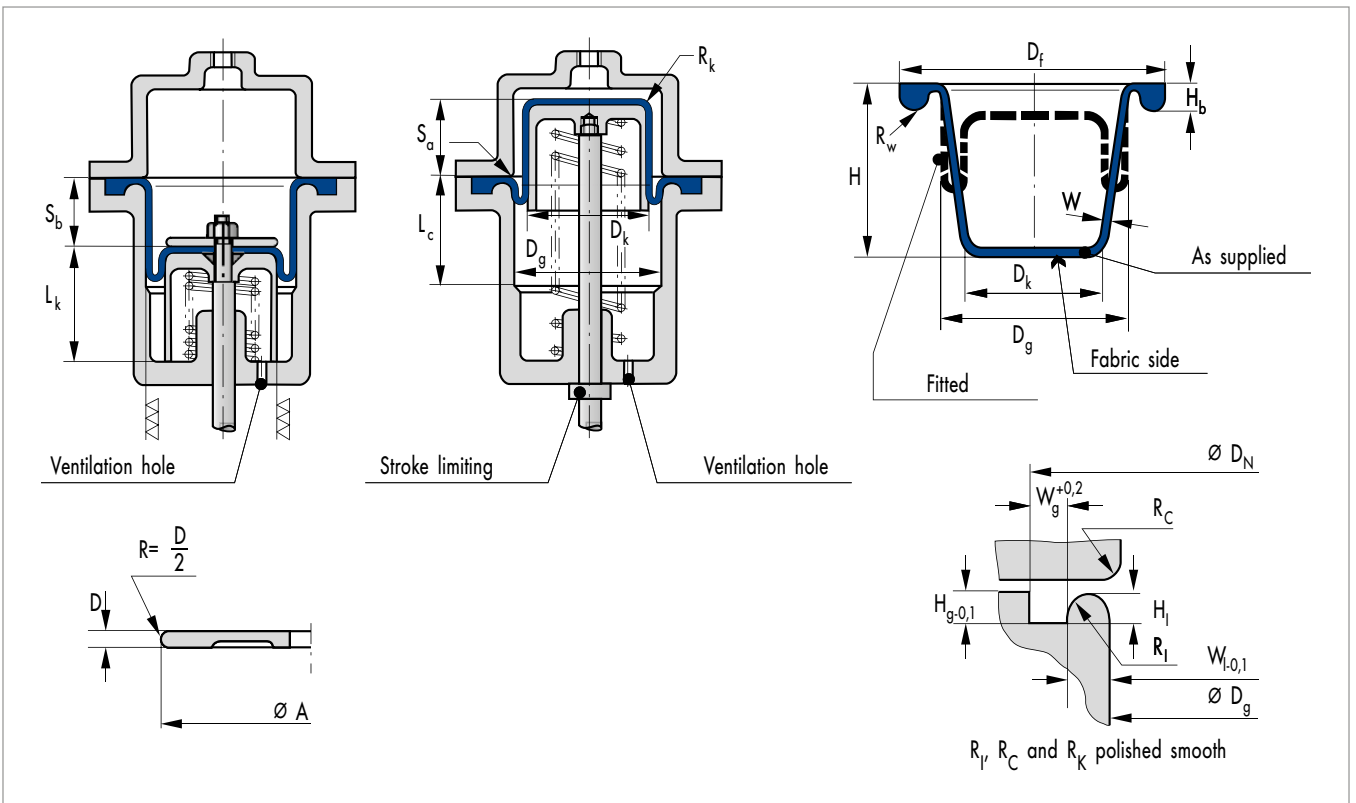

Cylinder Ø	D _g	up to 60 mm	up to 100 mm	up to 150 mm	>150 mm
Installation dimensions					
Piston Ø	D _k	D _g -5	D _g -10	D _g -10	D _g -10
Groove Ø	D _n	D _g +15	D _g +21	D _g +27,5	D _g +27,5
Piston radius	R _k	3,50	4,50	5,80	7,00
Cover radius	R _c	2,00	2,00	2,00	2,00
Groove depth	H _g	3,00	4,00	5,00	5,00
Groove width	W _g	4,00	5,50	7,20	7,20
Rim width	W _i	3,50	5,00	6,50	6,50
Rim height	H _i	2,30	3,10	3,50	3,50
Rim radius	R _i	1,75	2,50	3,25	3,25
Diaphragm dimensions					
Flange Ø	D _f	D _g +14	D _g +20	D _g +26	D _g +26
Wall thickness	W	0,45	0,55	0,80	1,00
Flange bead	H _b	3,60	5,00	6,30	6,30
Radius	R _w	1,75	2,50	3,25	3,25
Minimum length of finely machined areas					
on the piston	L _k	0,5 (H+S _a)	0,5 (H+S _a)	0,5 (H+S _a)	0,5 (H+S _a)
on the cylinder	L _c	0,5 (H+S _b)	0,5 (H+S _b)	0,5 (H+S _b)	0,5 (H+S _b)
Diaphragm stroke					
in one direction max.	S _a	H-8	H-14	H-20	H-20
in opposite direction max.	S _b	H-8	H-14	H-20	H-20
Fastening plate					
	a	D _k +2,9	D _k +4,1	D _k +5,6	D _k +6
	D	1,5	3,0	4,0	5,0